

Features

- Loop-powered, 4 to 20 mA transmitter
- Proven polymer capacitive sensor for fast response and calibration stability
- Platinum RTD temperature sensor
- 1/2 in MNPT or other process connections
- Operating temperature up to 300°F (150°C)
- 0 to 100% relative humidity
- Dew point 32°F to 300°F (0°C to 150°C)
- Second isolated 4 to 20 mA loop for temperature measurement (patented)
- Microcontroller electronics in Type 4X/IP67 enclosure

Options

- Integral display with user interface
- FM approved intrinsically safe/explosion-proof, Class I,II,III, Division 1 and 2, Groups A,B,C,D,E,F&G hazardous (classified) locations, or dust ignition proof

- English or metric fittings
- External display available with loop-powered supply and alarm

The DewPro MMR101 is a high-temperature loop-powered moisture and temperature transmitter. The transmitter is housed in a Type 4X/IP67 enclosure and features a simple two-wire or four-wire connection. The DewPro MMR101 uses a proven polymer capacitive sensor to provide a humidity measurement range of 0 to 100% RH with an accuracy of $\pm 2\%$ up to 149°F (65°C). A platinum RTD temperature sensor delivers temperature measurements in the range of 32°F to 300°F (0°C to 150°C). The optional integrated display with user interface provides full programming and diagnostic capability. In addition, the transmitter is FM approved intrinsically safe/explosion-proof for use in Class I,II,III, Division 1 and 2, Groups A,B,C,D,E,F&G hazardous (classified) locations.

With an operating temperature up to 300°F (150°C), the DewPro MMR101 is ideally suited for the harshest applications. The transmitter can report moisture content in relative humidity, dew point temperature, absolute humidity, and mixing ratio. Applications include food processing, high temperature solids drying, paint and coating/finishing processes, pharmaceutical processing, and other industrial applications.

DewPro[®] MMR101

High-Temperature Moisture Transmitter

DewPro MMR101 is a General Eastern product. General Eastern has joined other GE high-technology sensing businesses under a new name—GE Industrial, Sensing.



DewPro MMR101 Specifications

Sensing Element

Polymer; capacitance

RH Range

0 to 100%

RH Accuracy

±2% up to 150°F (65°C)

Temperature Sensor

Platinum RTD

Temperature Accuracy

±2°F (±1.1°C)

Operating Temperature Range

Process: 32°F to 300°F (0°C to 150°C)

Electronics: -40°F to 185°F (-40°C to 85°C)

Maximum Operating Pressure

150 psi (10.2 bar)

Electronics

Microcontroller operated, loop-powered

Loop Power Supply

24 VDC nominal, 12 to 30 VDC range

Outputs

Two fully isolated 4 to 20 mA current loops (moisture and temperature) patented (U.S. patent #5,677,476)

Hardware Selectable Units

0% to 100% RH, -40°F to 212°F or -40°C to 100°C dew point (up to 320°F or 150°C under system pressure), 0 to 1000 g/m³ absolute humidity, and 0 to 1000 g/kg mixing ratio dry air, wet bulb temperature, volume %

Standard Temperature Output

32°F to 300°F (0°C to 150°C) range

EX-CALIBRA

Autoryzowany dystrybutor

GE Measurement & Control Solutions

41-400 Mysłowice, ul. Portowa 25

tel.: 32 2239280, fax: 32 2239281

e-mail: ex-calibra@ex-calibra.pl

Internet: www.ex-calibra.pl



©2005 GE. All rights reserved.
920-061A

All specifications are subject to change for product improvement without notice.
DewPro® is a registered trademark of GE. GE® is a registered trademark of General Electric Co.

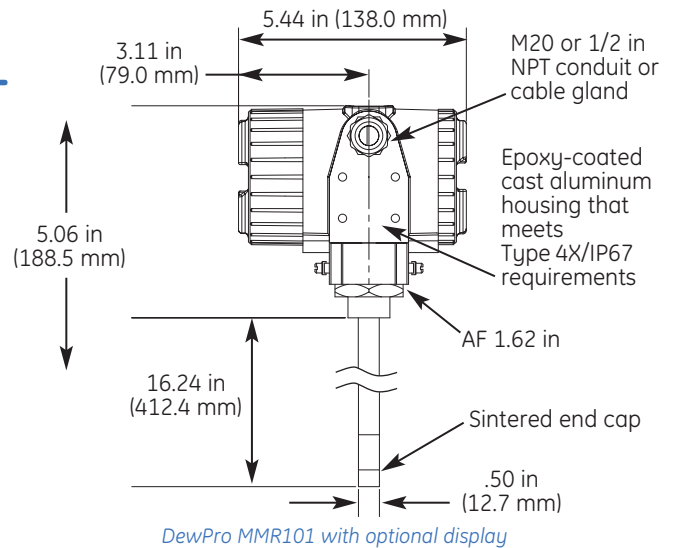

Optional Display

Four-digit numeric display with bar graph and matrix position indication. Four user interface keys for unit selections, output adjustments and ranging.

Protection

Type 4X/IP67

Probe Tube

16 in (400 mm) 316 stainless steel, 0.5 in diameter. Adjustable insertion length from 3 in (80 mm) to 14.25 in (362 mm). 9 in (225 mm) also available.

Typical Mounting Adapter

1/2 in tube x 1/2 in NPT-M or G 1/2 compression fitting; flanges and other sizes available upon request

Sensor Guard

40 micron sintered filter, 316 stainless steel cap

Weight

4.4 lb (2 kg)

European Compliance

Complies with EMC Directive 89/336/EEC and PED 97/23/EC for DN<25

Optional Certification/Approvals

- FM IS Class I,II,III, Division 1, Groups A,B,C,D,E,F&G, T4
- FM XP-IS Class I, Division 1, Groups A,B,C&D, T5
- FM NI Class I, Division 2, Groups A,B,C&D, T4A
DIP Class II,III, Division 1, Groups E,F&G, T4
- ATEX II 3G EEx nA IIC T4

